



Hydra-Cell[®]

Seal-less Pump Technology

Machine Tool

Reduce operating cost, Maximise productivity



Hydra-Cell® Machine Tool Coolant Pumps

Seal-less pumps for long life, high reliability, ultimate controllability and low total lifecycle costs.

High efficiency pumps for effective, controlled delivery of high pressure coolants for high speed machining.



- Neat oils
- Synthetic and semi-synthetic water mix fluids
- Milky soluble oils
- Coolants containing particles and abrasives

Hydra-Cell® Pumps are used in a wide variety of applications.



High pressure coolant delivery

Metal Cutting

High pressure coolant delivery is recognised to improve machining efficiency by enabling higher speeds and feeds to be employed. It enables chips to be formed more easily and removes them from the cutting zone more effectively. Better cooling performance increases tool life and enables tolerances to be maintained more easily. See video on web site www.Hydra-Cell.eu

Grinding

High pressure coolant delivery in grinding applications prevents wheel loading, freeing up the grit matrix and improving surface finish while reducing the need for time consuming wheel dressing.

Typical Liquids Pumped	Challenges in Pumping	The Hydra-Cell® Advantage
Neat oils... Hydrocarbon or synthetic	<ul style="list-style-type: none"> • May contain abrasive metal fines 	<ul style="list-style-type: none"> • Seal-less design can tolerate solids up to 500 µm in diameter
Milky soluble oil emulsions	<ul style="list-style-type: none"> • Water thin, can cause premature wear of dynamic seals immersed in the coolant 	<ul style="list-style-type: none"> • Seal-less, true positive displacement design pumps viscous and water thin liquids equally well
	<ul style="list-style-type: none"> • May contain abrasive metal fines 	<ul style="list-style-type: none"> • Seal-less design can tolerate solids up to 500 µm in diameter
	<ul style="list-style-type: none"> • May become aerated causing localised dry running conditions 	<ul style="list-style-type: none"> • Run dry capable
Synthetic and semi-synthetic water mix fluids	<ul style="list-style-type: none"> • May have poor lubricating properties causing premature wear of dynamic seals immersed in the coolant 	<ul style="list-style-type: none"> • Hydra-Cell does not rely on pumped liquid for internal lubrication
	<ul style="list-style-type: none"> • May become aerated causing localised dry running conditions 	<ul style="list-style-type: none"> • Run dry capable
	<ul style="list-style-type: none"> • May contain abrasive metal fines 	<ul style="list-style-type: none"> • Seal-less design can tolerate solids up to 500 µm in diameter
EDM Fluids... De-ionised water, Paraffinic hydrocarbon oils	<ul style="list-style-type: none"> • May contain particles and fines 	<ul style="list-style-type: none"> • Seal-less design can tolerate solids up to 500 µm in diameter
	<ul style="list-style-type: none"> • Chemically aggressive and non-lubricating, can cause problems for pumps with dynamic seals. 	<ul style="list-style-type: none"> • Eliminates seal and packing maintenance when pumping corrosive and non-lubricating liquids

Hydra-Cell®

Advantage

Hydra-Cell seal-less, positive-displacement pumps are ideal for pumping machine tool coolant at high pressure. Screw pumps, centrifugal pumps, gear pumps, and multi-piston pumps cannot match the rugged construction, flow rate control, energy efficiency, and versatility of Hydra-Cell pumps for your machine tool applications.



Run Dry Capable

The Seal-less design enables the Hydra-Cell pump to run dry indefinitely

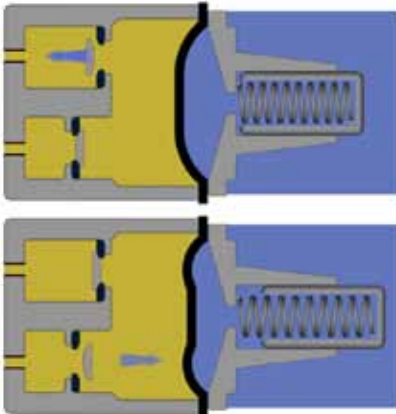

- Foaming coolant does not cause immediate damage* to the pump as in the case of pumps with dynamic seals, such as screw, gear and multistage centrifugal pumps which can cause immediate damage. ▼



* Prolonged pumping of foaming coolant can damage the Hydra-Cell pump

- Priming the pump is made easy as no special precautions have to be taken to make sure coolant is in the pump before it is started. Eliminating costly errors by operators and maintenance personnel and simplifying system design.

Minimal Filtration to Protect the Pump

- No mechanical seals or tight tolerances that need protection by fine filtration. (Some pumps such as gear and screw types wear excessively without good filtration.)
- In the case of light hard materials Titanium, Nickel alloys, very fine hard particles are produced with an even high chance of getting past the filtration system. The small hard particles causing even more damage.
- In the production environment everyday events can cause particles to go through the High pressure coolant pump such as
 - Poor filter element management
 - Particles dropping into the coolant during filter changes
 - Particles falling of the filter paper band
 - Filter paper tears

- The level of filtration can be determined by the cutting process and not by the pump requirement, saving operating costs.
- Elongated particles such as splinters created in the milling process may still pass through the filtration.
- Filtration systems may specify 10 -15 micron filtration however this is not an immediate "cut off".

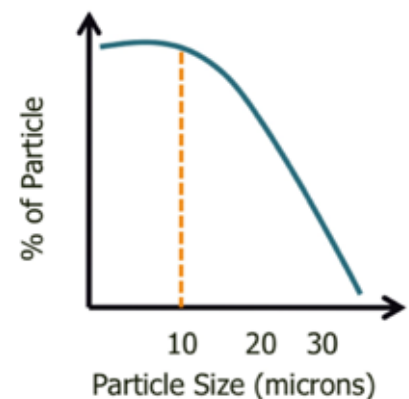

- Some processes such as deep hole drilling and grinding wheel cleaning may not need fine filtration. The Hydra-Cell's ability to handle coolants with particles simplifies the process design and management.
- Machining light Aluminium alloys, which produce fine light particles, can get past sedimentary, centrifugal and weir filtration systems causing problems for pumps with dynamic seals.

World class Energy Efficiency

- The true positive displacement pump action and seal-less design means that the energy losses are minimised even with water based emulsion coolants and overall efficiencies of up to 85% are achieved (Pump

shaft KW to hydraulic output). Saving thousands of euros per year in energy usage when compared with less efficient screw and multistage centrifugal pumps.

- No “leaking” dynamic seals means that Hydra-Cell energy efficiency is independent of coolant technology.

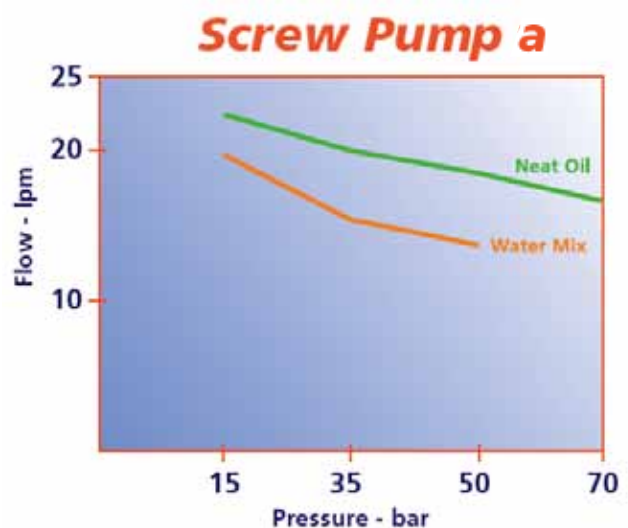
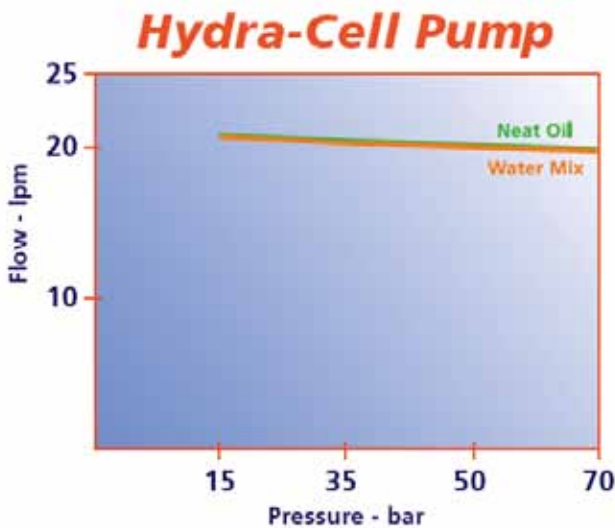
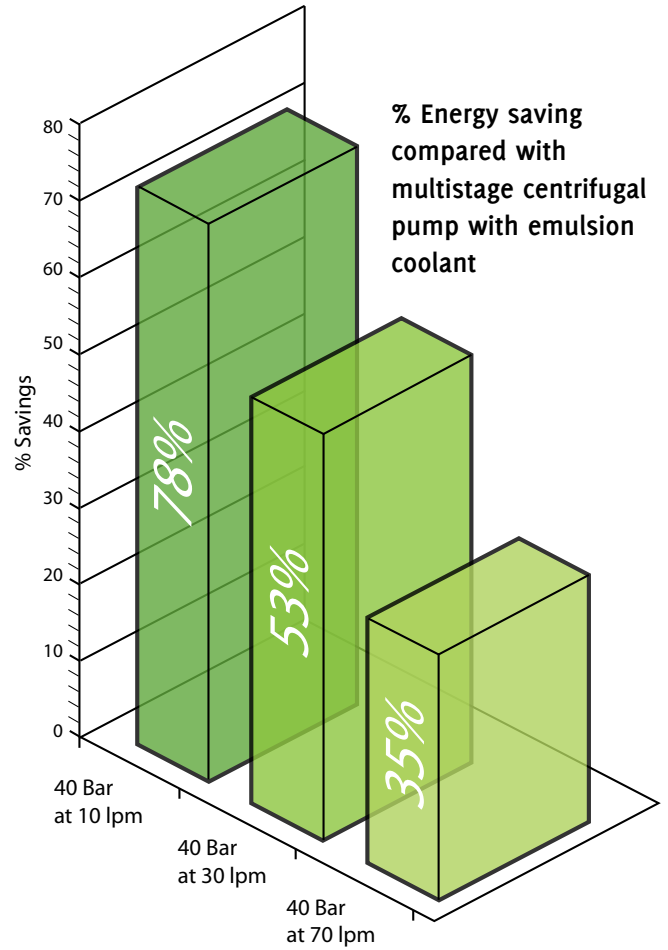
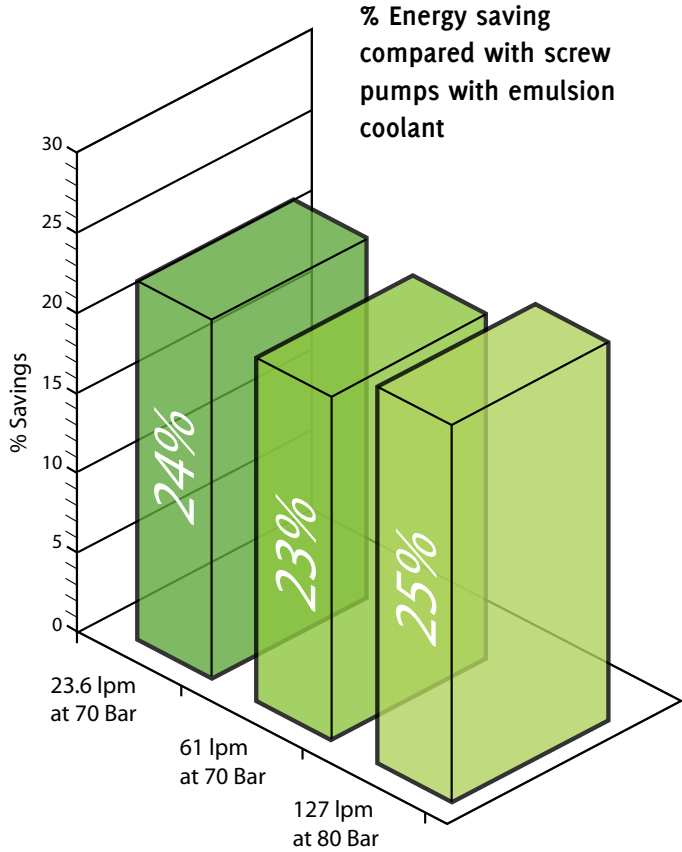

Note 1. Screw Pump ‘a’ is far less efficient at pumping thin, water based than when pumping more viscous neat oil whereas Hydra-Cell pumps both fluids with equal efficiency

Note 2. Screw Pump efficiency decreases as pressure is increased whereas Hydra-Cell is virtually as efficient at 70 bar as it is pumping at 15 bar.

Note 3. Screw pumps are more inefficient at low speeds making them less suitable for use with Variable Drive Motors

Hydra-Cell® Advantage

For high pressure coolant delivery, pumping pressures typically range between 35 and 100 bar with 60 bar being the most common requirement.

It is important to maintain this pressure and vary the coolant flow rate to suit the tool being used and the work being carried out in order to ensure the coolant reaches the cutting edge and performs optimally and consistently.



Controllable, Predictable, consistent coolant delivery

- Flow rate is independent of discharge pressure and coolant technology whether thin water based emulsion and thick neat oil coolants, as no dynamic seals to “leak” pressure. Giving predictable and consistent control of coolant flow and pressure by using an inverter.
 - Enables precise flow control
 - Removes tool blockages more easily
 - Better tool life predictability

Hydra-Cell pump

Neat oil ——— (blue line)
Water mix ——— (green line)

Screw pump

Neat oil ——— (yellow line)
Water mix ——— (orange line)

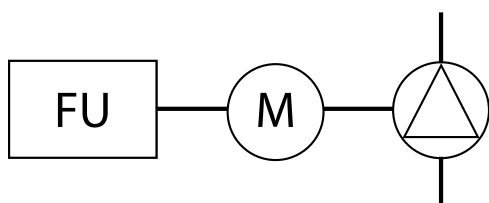
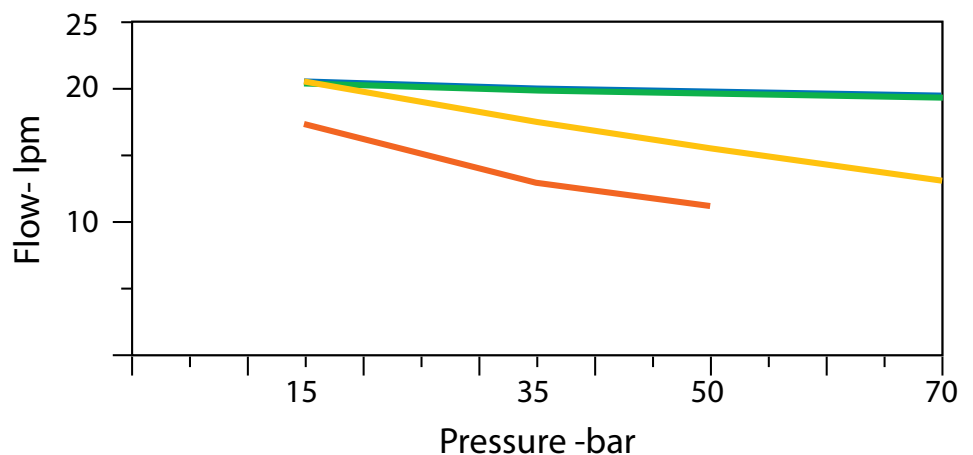

The simple diagram shows how, due to the Hydra-Cell's predictable and controllable behaviour, through open loop torque control of motor, the pressure and flow rate of coolant can be controlled. (Contact Wanner for more details)

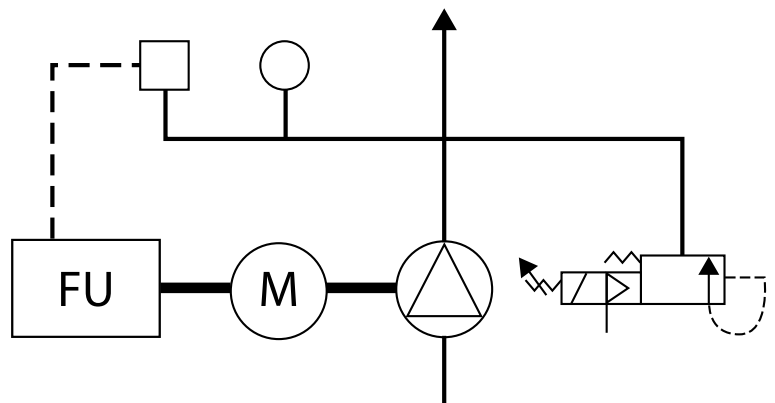

A screw pump requires more equipment, flow and pressure sensors, bypass valves etc to achieve the same result.

Energy savings from Ultimate flow controllability

- Excessive bypass flow of coolant can be eliminated by controlling the rpm of the pump to only deliver the flow rate of coolant required by the tool. This has two effects
 - Not wasting energy to drive the high pressure coolant pump at a higher flow rate than needed
 - Does not excessively heat the coolant so the coolant Chiller is not wasting energy.
- The rpm of the Hydra-Cell pump can be controlled from 5 rpm to 1500 rpm and the flow rate is directly proportional to pump rpm with an accuracy better than +/- 3%. The

flow rate can then be simply set by setting the pump rpm through machine code programing. This means that a flow sensor or pressure sensor is not needed.

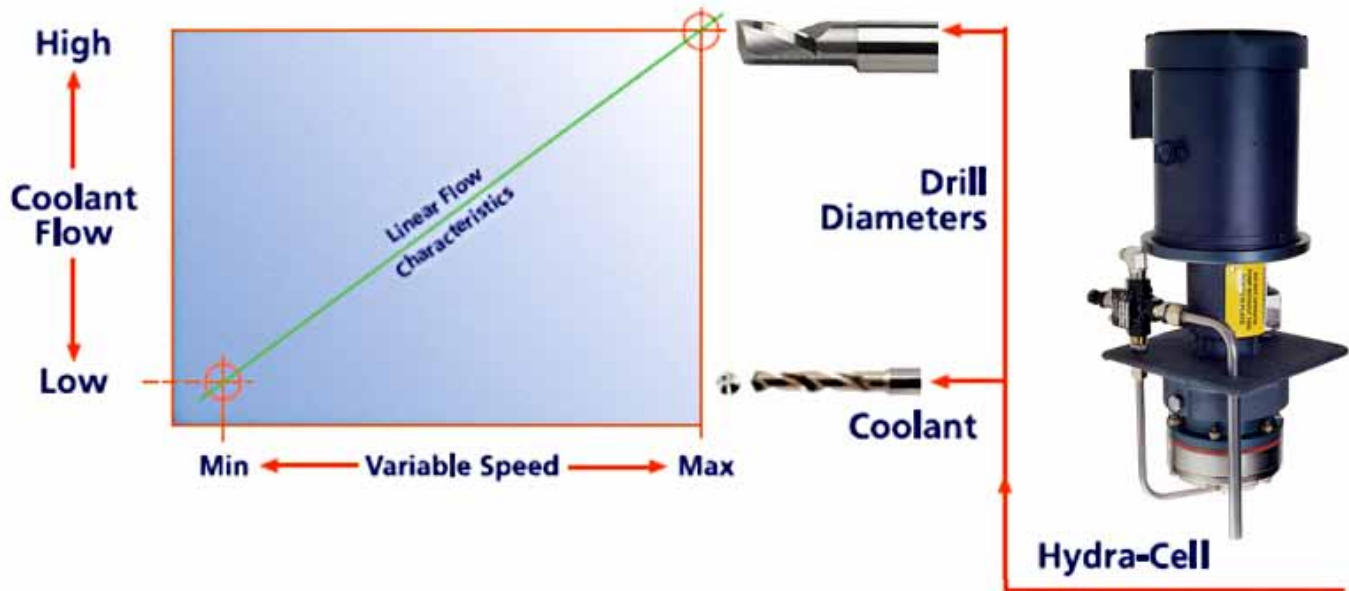

High reliability - With wide process operating window. Having no dynamic seals means high reliability; and no seal maintenance.

- No seals to wear or leak
- No tight tolerances that could be susceptible to damage by fines.
- No drop-off in performance due to seal wear.
- Runs dry indefinitely.
- No immediate damage by entrained air in coolant system.

Constant Flow Rate - Independent of pressure

With other types of pumps, flow rate decreases with increased pressure. Flow from a Hydra-Cell pump is independent of pressure and proportionate to the pump speed making it ideal for use in variable speed control systems.

- Enables precise flow control.
- Removes tool blockages more easily.
- Better tool life predictability.

Handles Dirty Fluids

Fines in the system, most commonly introduced unintentionally during filter changing, cause wear in screw and gear pumps that rely on close tolerances for operational efficiency.

Hydra-Cell pumps are designed to handle particles up to 500µm and more with ease, and even tolerate exceptionally hard fines generated in the machining of sapphire wafers (MOH 9.0) that destroy pumps with close tolerances and dynamic seals.

Low Maintenance

- Designed and built for long service life.
- Simple maintenance with no special tool requirements.
- No critical tolerances to be aware of during maintenance.
- In-situ repair possibilities... no costly removal and transportation to workshop or special clean environment.

Excellent Coolant Compatibility

Today's coolants vary widely in make-up and viscosity. Screw and gear pumps operate optimally with viscous neat oils that seal internal leak paths. They are somewhat less efficient when pumping water-thin coolants.

Hydra-Cell pumps can handle any type of coolant of any viscosity with the same high efficiency making it the pump of choice for high pressure coolant delivery.

Pumps:

- Neat Oils
- Milky oil emulsions
- Semi-synthetic
- Fully synthetic fluids
- Dirty coolants containing particles and sludge...with equal efficiency

Hydra-Cell® performance advantages



Screw Pumps Disadvantages	Hydra-Cell Advantages
<ul style="list-style-type: none"> • Close tolerances and running clearances require ultra-filtration (usually to 5 microns) 	<ul style="list-style-type: none"> • No close tolerances so no need for fine filtration.
<ul style="list-style-type: none"> • Performance characteristics sensitive to viscosity change. 	<ul style="list-style-type: none"> • Pumps thin and viscous liquids with equal efficiency.
<ul style="list-style-type: none"> • Mechanical seals and packing require maintenance, and replacement or adjustment. 	<ul style="list-style-type: none"> • The seal-less design of Hydra-Cell means that there are no seals or packing to leak or replace.
<ul style="list-style-type: none"> • Does not tolerate solids, fines, abrasives or particulates. 	<ul style="list-style-type: none"> • Seal-less pumping chamber with spring-loaded, vertical disk, check valves can pump fines up to 500 microns.
<ul style="list-style-type: none"> • Inefficient at low speeds (usually requires 1000 rpm min). 	<ul style="list-style-type: none"> • Runs at very low speeds and maintains outlet pressures. From 5 to 1500 rpm
<ul style="list-style-type: none"> • Depends on pumped liquid for sealing and hydrodynamic lubrication. Pumping non-lubricating, water thin grinding fluids can cause premature wear of the spindles. 	<ul style="list-style-type: none"> • No requirement for the pumped liquid to seal or lubricate.
<ul style="list-style-type: none"> • Contains bushings in the pumped liquid. 	<ul style="list-style-type: none"> • No bushings in the pumped liquid.
<ul style="list-style-type: none"> • Dry running and entrained air cause immediate damage. • Use of bypass valve to control discharge pressure for different tools wastes energy and excessively heats coolant heats coolant. • A complicated arrangement of speed control and bypass valve is required to control discharge pressure for different tools. 	<ul style="list-style-type: none"> • Can run dry without problem. Entrained air in the coolant does not lead to immediate failure. • Ultimate controllability removes the need for bypass, saving energy and keeping the coolant cooler. • Runs at very low speeds while maintaining outlet pressures, (from 5 to 1500 rpm) simplifying control functions.



Centrifugal Pumps (Multi-stage) Disadvantages	Hydra-Cell Advantages
<ul style="list-style-type: none"> Mechanical seals and packing require maintenance, and replacement or adjustment. 	<ul style="list-style-type: none"> The seal-less design of Hydra-Cell means that there are no seals or packing to leak or replace.
<ul style="list-style-type: none"> Particulates and fines in the pumped liquid will cause impeller wear and reduce pumping efficiency. 	<ul style="list-style-type: none"> Pumps particles and abrasives with ease.
<ul style="list-style-type: none"> Very inefficient at high pressures. 	<ul style="list-style-type: none"> Designed for high pressure delivery.
<ul style="list-style-type: none"> Dry running and air entrapment can cause catastrophic failure. 	<ul style="list-style-type: none"> Can run dry without problem. Entrained air in the coolant does not lead to immediate failure.
<ul style="list-style-type: none"> Ineffective at low speeds and flow rates. 	<ul style="list-style-type: none"> Runs at very low speeds and maintains outlet pressures. (from 5 to 1500 rpm)

External Gear Pump Disadvantages	Hydra-Cell Advantages
<ul style="list-style-type: none"> Mechanical seals and packing require maintenance, and replacement or adjustment. 	<ul style="list-style-type: none"> The seal-less design of Hydra-Cell means that there are no seals or packing to leak or replace.
<ul style="list-style-type: none"> Does not tolerate solids, abrasives, particulates or thin liquids. 	<ul style="list-style-type: none"> Seal-less pumping chamber and spring-loaded, horizontal disk check valves can pump solids, abrasive fillers and particulates while handling liquids thick or thin.
<ul style="list-style-type: none"> Component wear reduces accuracy and efficiency. 	<ul style="list-style-type: none"> No internal gears to wear so there is less maintenance and spare part replacement. • Efficiency is more stable.
<ul style="list-style-type: none"> Contains four bushings in the fluid area. 	<ul style="list-style-type: none"> No bushings in the pumped fluid.
<ul style="list-style-type: none"> Fixed end clearances. 	<ul style="list-style-type: none"> Design does not rely on clearances.
<ul style="list-style-type: none"> Efficiency drops at over 100 bar (1500 psi). 	<ul style="list-style-type: none"> Efficiency remains relatively constant over its range of operating pressures.
<ul style="list-style-type: none"> Depends on pumped liquid for lubrication. 	<ul style="list-style-type: none"> Sealed liquid chamber requires no lubrication.

Pump selection

Hydra-Cell® G-Series - High Performance, Positive Displacement Seal-less Coolant Pumps



Hydra-Cell® G-Series heavy duty coolant pumps are designed for the high pressure delivery of both neat oil and water mix metalworking coolants. Hydra-Cell is the pump of choice for stand-alone high pressure systems and its compact, seal-less design and high reliability make it a popular choice for machine integration.

Particulate fines occasionally find a route through even the best maintained coolant filtration systems. Unlike pumps that rely on fine tolerances to operate efficiently, Hydra-cell pumps are not affected by these abrasive particles and can even run dry without damage.

Options and accessories

- Pump motor adapters
- Pressure safety valves
- Tool kits
- Service kits
 - Diaphragm
 - Valve
 - Complete fluid end
- ATEX

Material options

- Liquid head material
 - Cast iron
 - Brass
 - 316 stainless steel
- Valve material
 - 17-4ph Stainless steel
 - Ceramic
 - Tungstan carbide
- Diaphragm material
 - Buna NX
 - Viton
 - EPDM

Pump flow and pressure rates

The range of Hydra-Cell pumps covers the vast majority of high pressure coolant delivery requirements from individual machines to several machines in production cells.

Hydra-Cell pumps and service are available worldwide through our Global Partner Network.

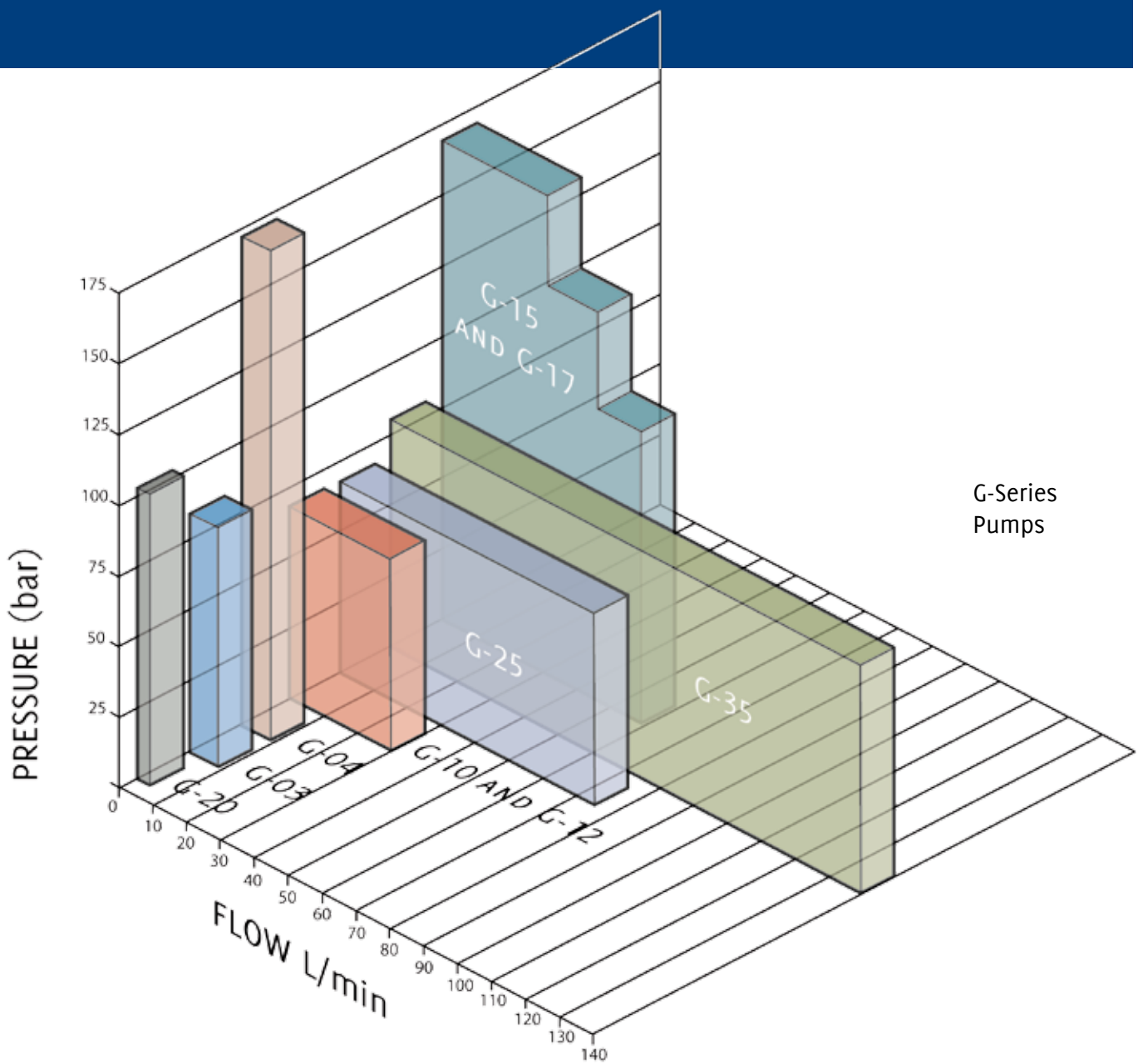

G-Series Pumps



WANNER INTERNATIONAL
Hampshire UK
t: +44 (0) 1252 816847
e: sales@wannerint.com

WANNER ENGINEERING
Minneapolis USA
t: (612) 332-5681
e: sales@wannereng.com

WANNER PUMPS
Shanghai CHINA
t: +86-21-6876 3700
e: sales@wannerpumps.com

WANNER PUMPS
Kowloon HONG KONG
t: +852 2112-1233
e: sales@wannerpumps.com

Hydra-Cell[®]
Seal-less Pump Technology

 **WANNER INTERNATIONAL**

www.hydra-cell.eu